

NEW BUCK CORPORATION MODEL 1110 VENT-FREE GAS HEATER

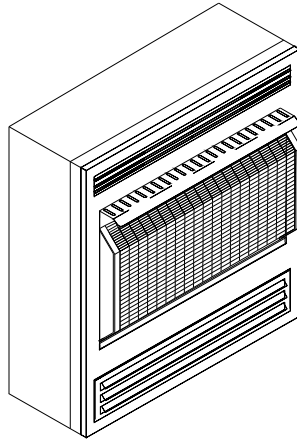

WARNING: If the information in this manual is not followed exactly, a fire or explosion may result causing property damage, personal injury or loss of life.

- Do not store or use gasoline or other flammable vapors and liquids in the vicinity of this or any other appliance.

WHAT TO DO IF YOU SMELL GAS

- Do not try to light any appliance.
- Do not touch any electrical switch; do not use any phone in your building.
- Immediately call your gas supplier from a neighbor's phone. Follow the gas supplier's instructions.
- If you cannot reach your gas supplier, call the fire department.
- Installation and service must be performed by a qualified installer, service agency or the gas supplier.

This is an unvented gas-fired heater. It uses air (oxygen) from the room in which it is installed. Provisions for adequate combustion and ventilation air must be provided. Refer to section "Producing Adequate Ventilation" page 13.

This appliance may be installed in an aftermarket, permanently located, manufactured (mobile) home, where not prohibited by local codes.

This appliance is only for use with the type of gas indicated on the rating plate. This appliance is not convertible for use with other gases.

INSTALLER: Leave this manual with the appliance.
CONSUMER: Retain this manual for future reference.

Manufacturer: NEW BUCK CORPORATION
P.O. Box 69
8000 Highway 226 South
Spruce Pine, NC 28777

March 2007

This appliance is intended for supplemental heating.

TABLE OF CONTENTS

Safety Information and Warnings.....	3
Product Identification.....	6
Product Features.....	7
Unpacking.....	7
Cautions.....	8
Installation.....	9
Producing Adequate Ventilation (Fresh Air for Combustion and Ventilation)....	13
Gas Connection.....	17
Connecting to Gas Supply	18
Gas Pressure Check.....	20
Log Placement.....	21
Lighting Instructions	22
Flame Check	26-27
Inspecting Pilot	26-27
Burner Flame Pattern.....	26-27
Wiring Diagram.....	28
Servicing.....	29
Cleaning and Maintenance.....	30
Troubleshooting.....	31
Technical Service.....	36
Parts List & Blown up View	37-40
Warranty	41

SAFETY INFORMATION WARNINGS

IMPORTANT: READ THIS OWNER'S MANUAL CAREFULLY AND COMPLETELY BEFORE TRYING TO ASSEMBLE, OPERATE, OR SERVICE THIS APPLIANCE. IMPROPER USE OF THESE LOGS CAN CAUSE SERIOUS INJURY OR DEATH FROM BURNS, FIRE, EXPLOSION, AND CARBON MONOXIDE POISONING.

Early signs of carbon monoxide poisoning resemble the flu, with headaches, dizziness, and/or nausea. If you have these signs, the heater may not be working properly. Get fresh air at once! Have burner serviced.

Some people-pregnant women, persons with heart or lung disease, anemia, those under the influence of alcohol, those at high altitudes-are more affected by carbon monoxide than others.

Make certain you understand and read all Warnings. Keep this manual for reference. It is your guide to safe and proper operation of this heater and logs.

CAUTION: Strong drafts, such as a ceiling fan placed directly in front of the heater (pulling from either direction) may create sooting. Sooting will discolor walls.

1. The installation must conform with local codes, or in the absence of local codes, with the *National Fuel Gas Code, ANSI Z223.1/NFPA54*.
2. This appliance may be installed in an After-Market* Manufactured (Mobile) Home, where not prohibited by state or local codes.

* (After-Market: Completion of sale, not for purpose of resale from the manufacturer.)

This appliance is only for use with the type of gas indicated on the rating plate. This appliance is not convertible for use with other gases.

NOTE: See Page 13, for "Producing Adequate Ventilation".

IMPORTANT: VENT-FREE HEATERS ADD MOISTURE TO THE AIR. ALTHOUGH THIS IS BENEFICIAL, INSTALLING HEATER IN ROOMS WITHOUT ADEQUATE VENTILATION MAY CAUSE MILDEW TO FORM FROM TOO MUCH MOISTURE.

3. Never install this heater:
 - in a recreational vehicle, bathroom.
 - where curtains, furniture, clothing, or other flammable objects are less than 24" from the front of the heater
 - in high traffic areas
 - in windy areas
4. Two models are available. One specific model for propane(LP), and one for natural gas. Use the correct type gas for your home. Do not convert from one gas type to another.

WARNING

This appliance is equipped for (natural or propane) gas .
Field conversion is not permitted.

5. If this heater is used with propane gas, do not place propane supply tank (s) inside any structure.
6. **What To Do IF You Smell Gas:**
Shut off gas supply.
 - Do not try to light any appliance.
 - Do not touch any electrical switch; do not use any phone in your building.
 - Immediately call your gas supplier from a neighbor's phone.
Follow the gas supplier's instructions.
 - If you cannot reach your gas supplier, call the fire department.
7. When operated for the first time, the logs may emit a "paper burning" smell. This smell will gradually diminish and will be totally eliminated after the first few hours of operation. Run the gas logs with the flue damper open during this time. Do not use blower at this time.
8. **"This heater shall not be installed in a confined space or unusually tight construction unless provisions are provided for adequate combustion and ventilation air."** See *"Producing Adequate Ventilation"*, page 13.
9. Surface of gas logs becomes very hot when operating. Keep children and adults away from hot surface. Gas logs will remain hot for sometime after shutdown. Allow surface to cool before touching.
10. **Do not place clothing or other flammable material on or near the appliance.**
11. If equipped, fresh air damper must be closed.
12. **Keep appliance area clean and free from combustible materials, gasoline, and other flammable flammable vapors and liquids.**
13. If burner shuts off, do not relight until you provide fresh outside air. If burner continues to shut off, have unit serviced.
14. **Do not use this heater if any part has been under water. Immediately call qualified service technician to inspect the room heater and to replace any part of the control system and any gas control which has been under water.**
15. Turn off the heater and let cool before servicing.
16. These logs are made of bonded fiber. When removing logs and base, do not damage the bonded material. If the material is damaged extensively, loose fiber dust could be emitted into the air.
17. **Any safety screen or guard removed for servicing an appliance must be replaced prior to operating the heater.**
18. **This appliance is intended for supplemental heating.**
19. **"WARNING: Any change to this heater or its controls can be dangerous."**
20. **Installation and repairs should be performed by a qualified service person. The appliance should be inspected before use and at least annually by a professional service person. More frequent cleaning may be required due to excessive lint from carpeting, bedding material, etc. It is imperative that control compartments, burners and circulating air passageways of the appliance be kept clean.**

21. All heater screens must be kept clean when operating the gas logs.
22. **"WARNING: Failure to keep the primary air opening(s) of the burner(s) clean may result in sooting and property damage."**
23. Do not use this heater for burning trash or cooking. Never place matches, paper, garbage, or any other material on top of logs or into the flames.
24. **Do not install or operate this heater in areas where impurities in the air exist (such as tobacco smoke or heavy cooking grease). Particles from impurities may discolor walls.**
25. **Due to high temperatures, the appliance should be located out of traffic and away from furniture and draperies.**
26. **Children and adults should be alerted to the hazards of high surface temperature and should stay away to avoid burns or clothing ignition.**
27. **Young children should be carefully supervised when they are in the same room with the appliance.**
28. **An unvented room heater having an input rating of more than 10,000 Btu per hour shall not be installed in a bathroom or bedroom.**
29. **The appliance and its appliance main gas valve must be disconnected from the gas supply piping system during any pressure testing of that system at test pressure in excess of 1/2 psi (3.5 kPa).**
30. **The appliance must be isolated from the gas supply piping system by closing its equipment shut-off valve during any pressure testing of the gas supply piping system at test pressures equal to or less than 1/2 psi (3.5 kPa).**
31. **"WARNING: Do not allow fans to blow directly into fireplace. Avoid any drafts that alter burner flame patterns."**
32. **"WARNING: Do not use a blower insert, heat exchanger insert or other accessory not approved for use with this heater."**

PRODUCT IDENTIFICATION

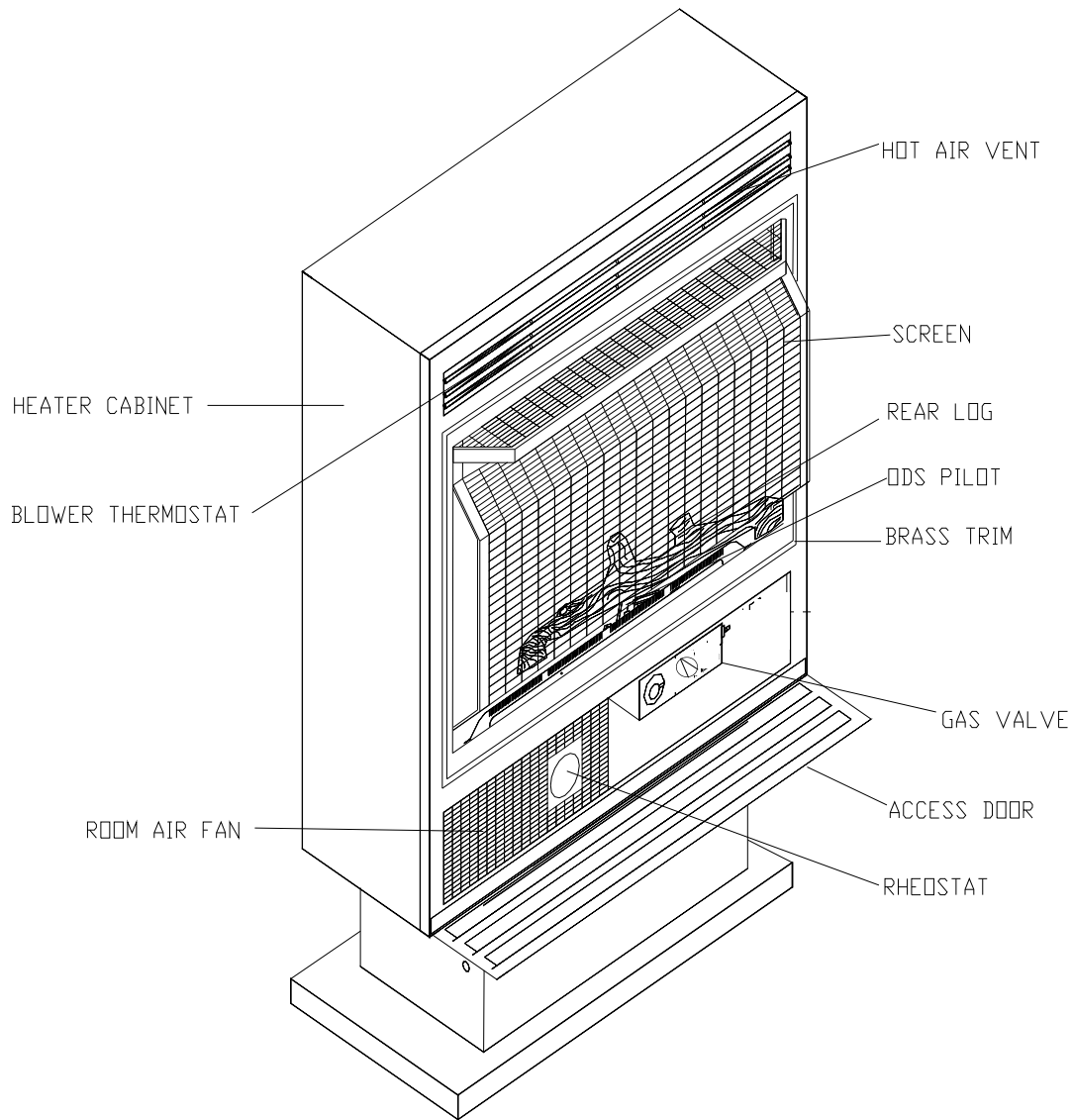

Figure 1

WARNING: Installation and repairs should be performed by a qualified service person. The appliance should be inspected before use and at least annually by a professional service person. More frequent cleaning may be required due to excessive lint from carpeting, bedding material, etc. It is imperative that control compartments, burners and circulating air passageways of the appliance be kept clean.

PRODUCT FEATURES

SAFETY DEVICE

This heater has a pilot with an Oxygen Depletion Sensor Shutoff System (ODS). The ODS/pilot is a required feature for vent-free room heaters. The ODS/pilot shuts off the heater if there is not enough (oxygen) fresh air.

PIEZO IGNITION SYSTEM

This heater has a piezo igniter. This system requires no matches, batteries, or other sources to light the heater.

This appliance is only for use with the type of gas indicated on the rating plate. This appliance is not convertible for use with other gases.

Model 1110 P* or N*- (Sensing or Modulating Bulb) - This heater has a thermostat sensing bulb. This bulb will turn the unit on and off. It will not modulate the flame up or down due to 10,00 BTU.

*P - Propane or LP (Liquid Petroleum)

*N - Natural gas

UNPACKING

1. Remove all protective packaging applied to heater for shipment.
2. Check heater for any shipping damage. If heater is damaged, promptly inform the dealer from whom you made the purchase.
3. Lift heater by each bottom corner.

“WARNING: Any change to this heater or its controls can be dangerous.”

CAUTION

THIS HEATER CREATES WARM AIR CURRENTS. THESE CURRENTS MOVE HEAT TO WALL SURFACES NEXT TO HEATER. DO NOT INSTALL HEATER WHERE IMPURITIES IN THE AIR MAY EXIST.

MINIMUM CLEARANCES TO COMBUSTIBLE CONSTRUCTION

NOTE: FOR GARAGE INSTALLATION

- Heater pilot and burner must be at least **18"** off the floor.
- Locate heater **AWAY FROM ANY MOVING VEHICLE.**
- **Keep appliance area clear and free from combustible materials, gasoline and other flammable vapors and liquids.**

For convenience and efficiency, install heater:

- * in easy access locations
- * in coolest part of room
- * near an electrical outlet

Minimum Clearances are as follows:

42" from the top of the appliance to the ceiling. 5" from the right front corner of the appliance to an adjacent side wall, and 5" from the left side of the appliance to an adjacent side wall. 7" from the bottom of the appliance to the top surface of carpeting, tile or other combustible materials in the area described. See figure 2 below.

- **The installation must conform with local codes or, in the absence of local codes, with the *National Fuel Gas Code, ANSI Z223.1/NFPA 54.***

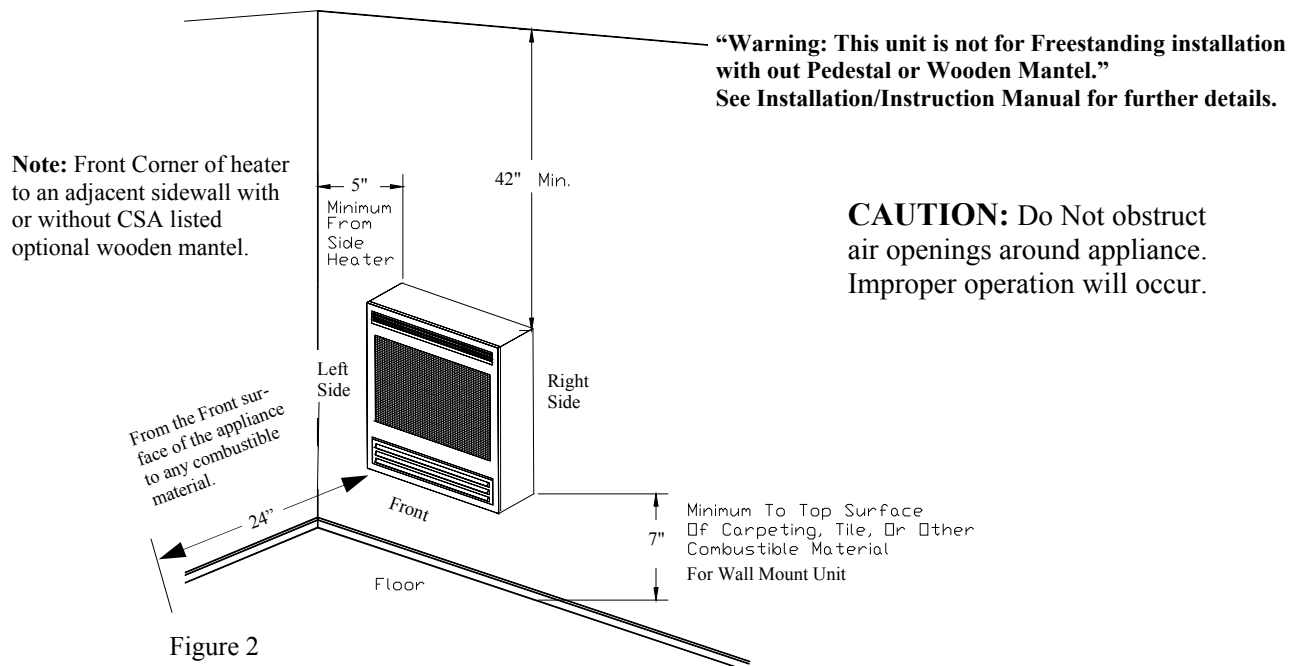

NOTE: This heater may be installed three different ways:

- 1. Wall Mounted**
- 2. Freestanding heater (with optional pedestal)**
- 3. Freestanding (with optional wooden mantel)**

NOTE: Do not set unit flat on any surface without Pedestal or Wooden Mantel.

WALL MOUNT INSTALLATION:

1. After determining the location for the heater, unfold the template provided and place the bottom of the template a minimum of 7" from bottom of unit to floor.

NOTE: Be sure to level the template before punching the holes.

2. With the template in place and the four black dots centered on studs, punch the four centers marked in the black dots with a sharp pointed object. Insert the four wood screws provided with the unit into the four punched holes.

NOTE: Leave 5/8" of the screw projecting from the finished wall.

Figure 3

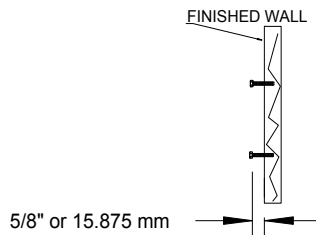

For sheet rock walls, use wing nuts or anchor wings. Remove the wing nut from the bolt. Place a nut and washer with the same thread and size on the bolt. Push the wing nut through the wall surface allowing the wings to spread. Tighten the nut that you placed on the bolt, leaving the required 5/8" between the back of the bolt head and the finished wall.

Figure 4

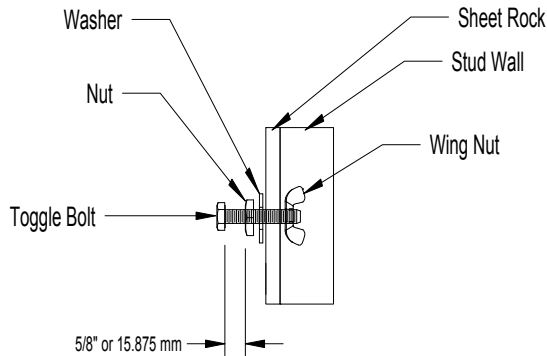

3. Lift heater by each bottom corner and place the round part of the tear drop punch out over each screw head. Gently push down until the body of the screw is at the end of the slot.

NOTE: Make sure unit is level.

4. Now you are ready to hook up the gas line. The Model 1110 allows for a rear or bottom connection for the gas line. See “Gas Connection” on page 17 for details.

CLEANING INFORMATION:

Cleaning is a vital part of the life of your stove. In order to properly clean the unit, remove the front. To remove: use Phillips screwdriver to loosen four screws in the sides of the front. You will find that the front is easily removed in one piece.

Next you must remove the log(s) from the burner base. Gently place your hands, one on each side of the log(s) and lift upward. Do not apply too much force on the log(s), this may cause damage to the fiber material.

Figure 5

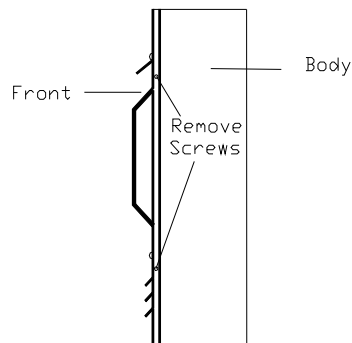

A vacuum cleaner works well for removal of dust and debris from around the burner and logs. To remove the burner, use a tool with an extension to loosen the screw in the base. The screw is located between the log and the actual base. Simply slide the base out of the unit. **NOTE:** Do not use a pin or any sharp object to clean the pilot.

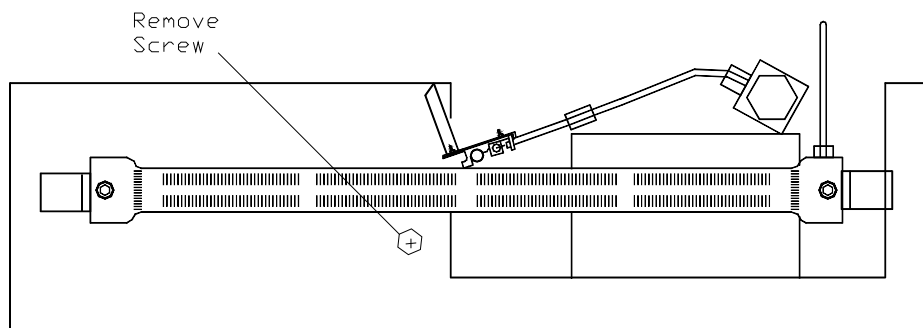

NOTE: Any parts that are removed while cleaning must be replaced before operating the appliance.

Figure 6

FREESTANDING WITH OPTIONAL PEDESTAL INSTALLATION

1. Place heater on backside and center the pedestal on the bottom. Mark the 4 pre-punched holes in the pedestal angle. Use the 4 self-tapping screws provided with the pedestal to drill the 4 marked spots. Secure the pedestal to the bottom of the unit.

NOTE: If the gas line is run through the floor, you may want to drill a hole in the bottom of the pedestal.

2. The pedestal must be secured to the floor. One option is to drill holes in the top side of the bottom of the pedestal. Use screws or “EII” brackets to fasten pedestal to the floor.

IMPORTANT: THE 1110 FREESTANDING UNIT MUST BE INSTALLED ON A FLAT SURFACE (SUCH AS A WOOD PANEL, METAL OR HARDWOOD FLOORS.)

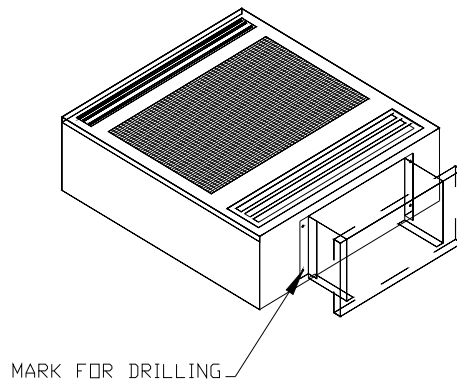

FREESTANDING OPTIONAL WOODEN MANTEL INSTALLATION

Use the two (2) metal mounting Z-Brackets provided to secure the 1110 into the wooden mantel, wood screws provided to secure the brackets in place.

IMPORTANT! The Z-Brackets must be properly installed. Failure to install the Z-Brackets may cause property damage or personal injury.

Use the four (4) sheet metal screws provided to secure the mounting brackets to the rear of the stove. Insert the screws into the back of the unit.

With the brackets secured to the unit. From the rear slide the unit into the opening of the mantel, centering from left to right.

With the four (4) wood screws provided secure the brackets to the rear of the mantel. See Figure 7, page 12.

NOTE: Connect gas line and check for leaks before placing the heater and mantel against the wall. See “Gas Connection” on page 17.

OPTION: Fasten the wooden mantel to the wall. Use “EII” brackets at top or bottom corners.

MOUNTING BRACKET VIEW FREE-STANDING OPTIONAL DELUXE FINISHED MANTEL

NOTE: "MODEL 1110 TO BE USED WITH NEW BUCK CORP. MANTEL ONLY, PART # PAKDM1127." IF USED WITH ANY OTHER MANTEL THE WARRANTY WILL BE VOID.

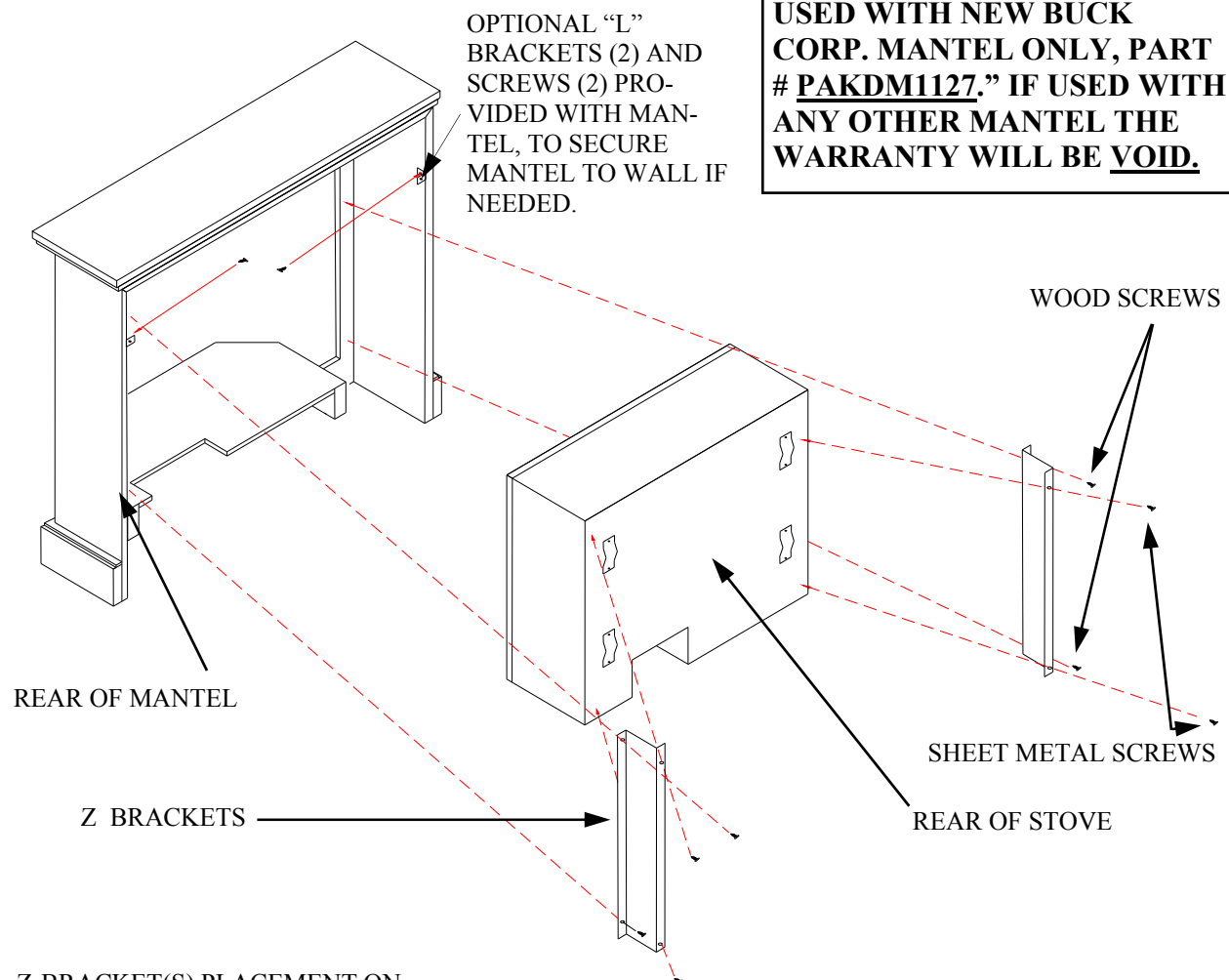

Z-BRACKET(S) PLACEMENT ON STOVE

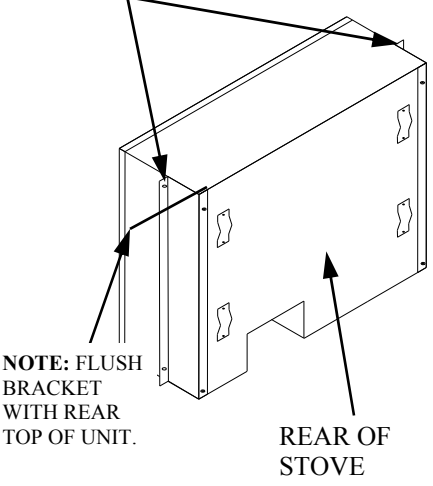

Z-BRACKETS MOUNTED (SCREWED) TO THE REAR OF THE STOVE AND SECURED (SCREWED) TO THE INSIDE REAR OF THE FRONT OF THE MANTEL.

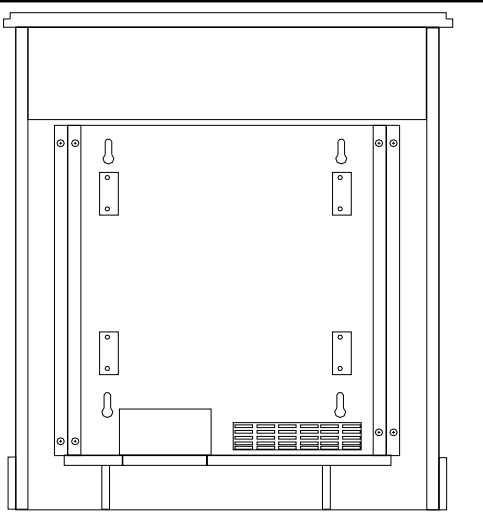

Figure 7

PRODUCING ADEQUATE VENTILATION

This section is for residential or manufactured (mobile) installation

“This heater shall not be installed in a confined space or unusually tight construction unless provisions are adequate combustion and ventilation air.”

The **National Fuel Gas Code, ANSI Z223.1/NFPA 54** defines a confined space as a space whose volume is less than 50 cubic feet per 1,000 BTU per hour (4.8m³ per kw) of the aggregate input rating of all appliances installed in that space and an unconfined space as a space whose volume is not less than 50 cubic feet per 1,000 BTU per hour (4.8m³ per kw) of the aggregate input rating of all appliances installed in that space. Rooms communicating directly with the space in which the appliances are installed, through openings not furnished with doors, are considered a part of the unconfined space.

“WARNING: IF THE AREA IN WHICH THE HEATER MAY BE OPERATED IS SMALLER THAN THAT DEFINED AS AN UNCONFINED SPACE OR IF THE BUILDING IS OF UNUSUALLY TIGHT CONSTRUCTION, PROVIDE ADEQUATE COMBUSTION AND VENTILATION AIR BY ONE OF THE METHODS DESCRIBED IN THE NATIONAL FUEL GAS CODE, ANSI Z223.1/NFPA 54, SECTION 5.3 OR APPLICABLE LOCAL CODES.”

Unusually tight construction is defined as construction where:

- Walls and ceilings exposed to the outside atmosphere have a continuous water vapor retarder with a rating of 1 perm (6×10^{-11} kg per pa-sec-m²) or less with openings gasketed or sealed;
- Weather stripping has been added on openable windows and doors, and
- Caulking or sealants are applied to areas such as joints around window and door frames, between sole plates and floors, between wall-ceiling joints, between wall panels, at penetrations for plumbing, electrical, and gas lines, and at other openings.

NOTE: SOME AREAS IN THE UNITED STATES HAVE HIGHER REQUIREMENTS FOR CUBIC FEET PER 1000 BTU/ HOUR INPUT. (EX. CINCINNATI, OHIO CODES REQUIRE 70 CUBIC FEET). CHECK YOUR LOCAL CODE BEFORE INSTALLATION.

DETERMINING FRESH-AIR FLOW FOR HEATER LOCATION

DETERMINE IF YOU HAVE A CONFINED OR UNCONFINED SPACE

Use this worksheet to determine if you have confined or unconfined space.

SPACE: Includes the room in which you will install heater plus adjoining rooms with doorless passageways or ventilation grills between the rooms.

1. **Determine the volume of the space (length x width x height).**

Length x Width x Height = _____ cu.ft.(volume of space)

EXAMPLE: 20 ft.(Length) x 16 ft.(Width) x 8 ft.(ceiling Height)=
2560 cu. ft. (volume of space)

If additional ventilation to adjoining room is supplied with grills or openings, add the volume of these rooms to the total volume of the space.

2. **Divide the space volume by 50 cubic feet to determine the maximum BTU/Hr the space can support.**

_____ (volume of space)/50 cu. ft. =maximum BTU/Hr the space can support)

EXAMPLE: 2560 cu. ft. (volume of space /50 cu. Ft. = 51.2 or
51200 (maximum BTU/Hr the space can support)

3. Add the BTU/Hr of all fuel burning appliances in the space.

Vent-free heater	_____	BTU/Hr
Gas water heater*	_____	BTU/Hr
Gas furnace	_____	BTU/Hr
Vented gas heater	_____	BTU/Hr
Gas fireplace logs	_____	BTU/Hr
Other gas appliances*	+ _____	BTU/Hr
Total	= _____	BTU/Hr

Example: Gas water heater 40000 BTU/Hr
Vent-free heater + 18000 BTU/Hr
Total = 58000 BTU/Hr

*Does not include direct-vent gas appliances. Direct-vent draws combustion air from the outdoors and vents to the outdoors.

4. Compare the maximum BTU/Hr the space can support with the actual amount of BTU/Hr used.

_____ BTU/Hr (maximum the space can support)
_____ BTU/Hr (actual amount of BTU/Hr used)

Example: 51200 BTU/Hr (maximum the space can support)
58000 BTU/Hr (actual amount of BTU/Hr used)

The space in the above example is a confined space because the actual BTU/Hr used is more than the maximum BTU/Hr the space can support. You must provide additional fresh air. Your options are as follows: A. Rework worksheet, adding the space of an adjoining room. If the extra space provides an unconfined space, remove door to adjoining room or add ventilation grills between rooms. See "Ventilation Air From Inside Building", page 21.

B. Vent room directly to the outdoors. See "Ventilation Air From Outdoors", page 22.

C. Install a lower BTU/Hr heater, if lower BTU/Hr size makes room unconfined.

If the actual BTU/Hr used is less than the maximum BTU/Hr the space can support, the space is an unconfined space. You will need no additional fresh air ventilation.

WARNING: YOU MUST PROVIDE ADDITIONAL VENTILATION AIR IN A CONFINED SPACE

VENTILATION AIR

VENTILATION AIR FROM INSIDE BUILDING

This fresh air would come from an adjoining unconfined space. When venting to an adjoining space, you must provide two permanent openings: one within 12" of the ceiling and one within 12" of the floor on the wall connecting the two spaces (see Options 1 and 2, Figure 8). You can also remove door into adjoining room (see Option 3, in Figure 8).

WARNING

REWORK WORKSHEET, ADDING THE SPACE OF THE ADJOINING UNCONFINED SPACE. THE COMBINED SPACES MUST HAVE ENOUGH FRESH AIR TO SUPPLY ALL APPLIANCES IN BOTH SPACES.

NOTE: Each opening shall have a minimum free area of 1 square inch per 1000 BTU's per hour of the total input rating of all gas utilization equipment in the confined space, but not less than 100 square inches.

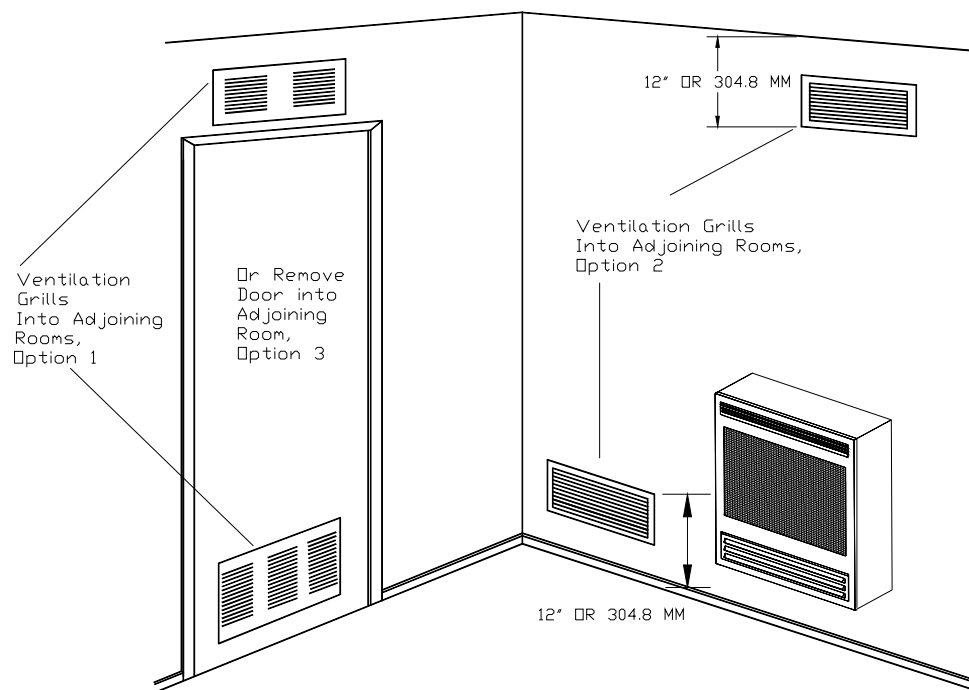

Figure 8

WARNING

THIS APPLIANCE MUST HAVE FRESH AIR FOR PROPER OPERATION. IF NOT, POOR FUEL COMBUSTION COULD RESULT. READ THE FOLLOWING INSTRUCTIONS TO ENSURE PROPER FRESH AIR FOR THIS AND OTHER FUEL-BURNING APPLIANCES IN YOUR HOME.

VENTILATION AIR FROM OUTDOORS

Provide extra fresh air by using ventilation grills or ducts. You must provide two permanent openings: one within 12" of the ceiling and one within 12" of the floor. Connect these items directly to the outdoors. These spaces include attics and crawl spaces. Follow the **National Fuel Gas Code NFPA 54/ANSI Z223.1**, Section 5.3, "Air For Combustion and Ventilation" for required size of ventilation grills or ducts.

IMPORTANT: Do not provide openings for inlet air into attic if attic has a thermostat-controlled power vent. Heated air entering the attic will activate the power unit.

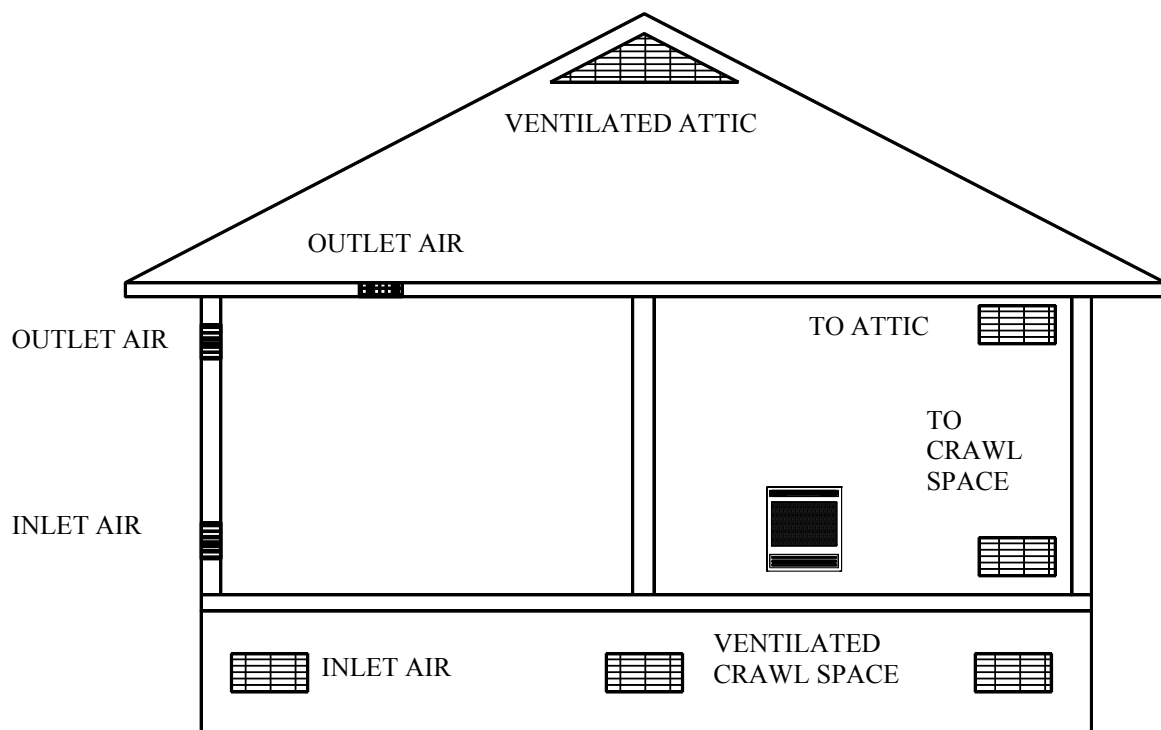

Figure 9

WARNING: ANY CHANGE TO THIS HEATER OR ITS CONTROLS CAN BE DANGEROUS.

GAS CONNECTION

Check gas type. Use only the type of gas indicated on the valve rating plate. If the type of gas listed on the plate is not your type of gas supply, **DO NOT INSTALL.** Contact your dealer for proper model. Always use an external regulator for all LP heaters to reduce the supply tank pressure to a maximum of 13" W.C. This is in addition to the regulator furnished with the heater.

WARNING: CONNECTION DIRECTLY TO AN UNREGULATED LP TANK CAN CAUSE AN EXPLOSION.

The normal gas connection is 3/8" N.P.T. made at the left side (facing the front of the appliance) of the appliance. If a right side connection is desired, the connecting pipe may be led under the rear of the burner base to terminate at the right side for connection to the inlet of the valve.

NOTE: The connecting pipe must be internally tinned copper tubing for use with natural gas. *Test for leaks using a solution of soap and water after completing the connection. DO NOT USE OPEN FLAME.*

WARNING: Installation and repairs should be performed by a qualified service person. The appliance should be inspected before use and at least annually by a professional service person. More frequent cleaning may be required due to excessive lint from carpeting, bedding material, etc. It is imperative that control compartments, burners and circulating air passageways of the appliance be kept clean.

CONNECTING TO A GAS SUPPLY

CAUTION: NEVER CONNECT HEATER DIRECTLY TO THE PROPANE SUPPLY. THIS HEATER REQUIRES AN EXTERNAL REGULATOR (NOT SUPPLIED). INSTALL THE EXTERNAL REGULATOR BETWEEN THE HEATER AND THE PROPANE SUPPLY.

The installer must supply the external regulator for liquid propane gas. The external regulator will reduce incoming gas pressure. You must reduce incoming gas pressure to between 11" and 14" of water. If incoming gas pressure is not reduced, heater regulator damage will occur. Install external regulator with the vent pointing down.

You must also install a sediment trap. Locate the sediment trap where it is within reach for cleaning. A sediment trap filters moisture and contaminants. This also helps to keep the heater controls clean. If sediment trap is missing or installed wrong, your unit will not run properly.

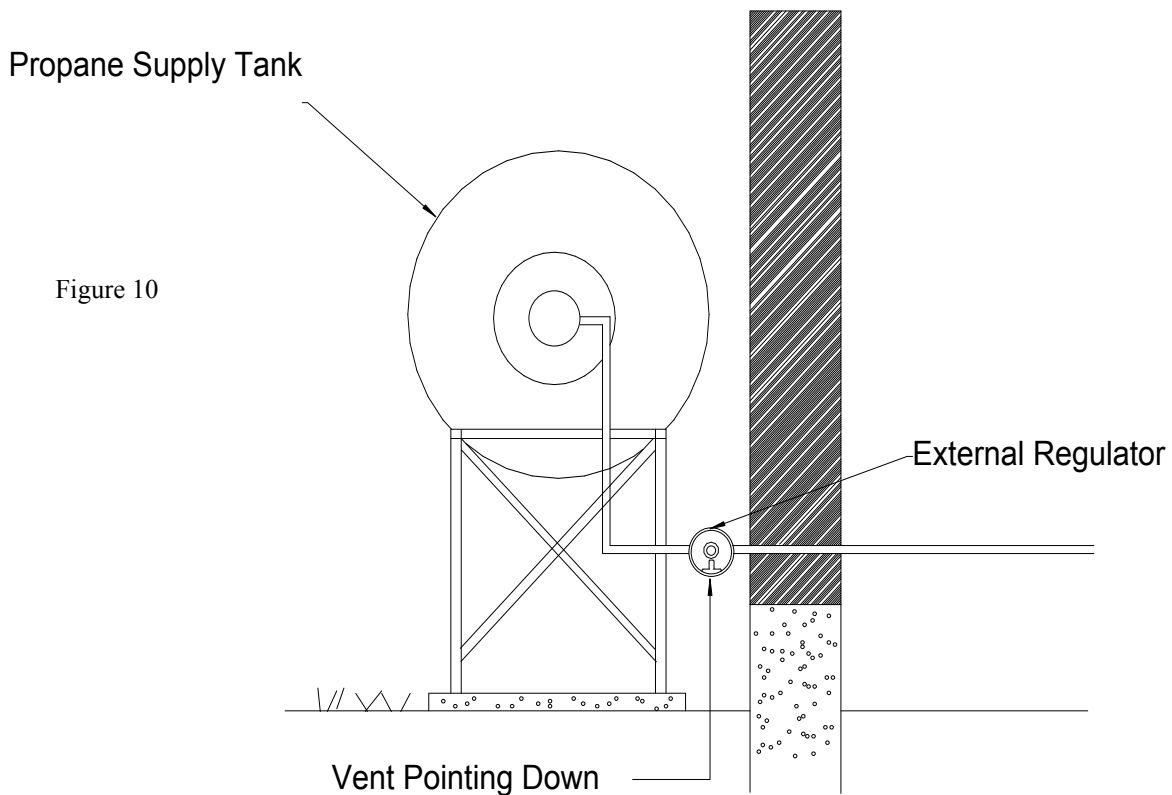

CAUTION: Use only new black iron or steel pipe. Internally tinned copper tubing may be used in certain areas. Check state and local codes. Use pipe of 1/2" or greater in diameter to allow proper gas volume. If piping is too small, undue loss of pressure will occur.

Installation must include manual shutoff valve and plugged 1/2" NPT tap. Locate NPT tap within reach for test gauge hook-up. NPT tap must be upstream from unit.

Apply pipe joint sealant lightly to male threads. This will prevent excess sealant from going into pipe. Excess sealant in pipe could result in clogged heater valves.

CAUTION: USE PIPE JOINT SEALANT THAT IS RESISTANT TO LIQUID PETROLEUM (LP) GAS.

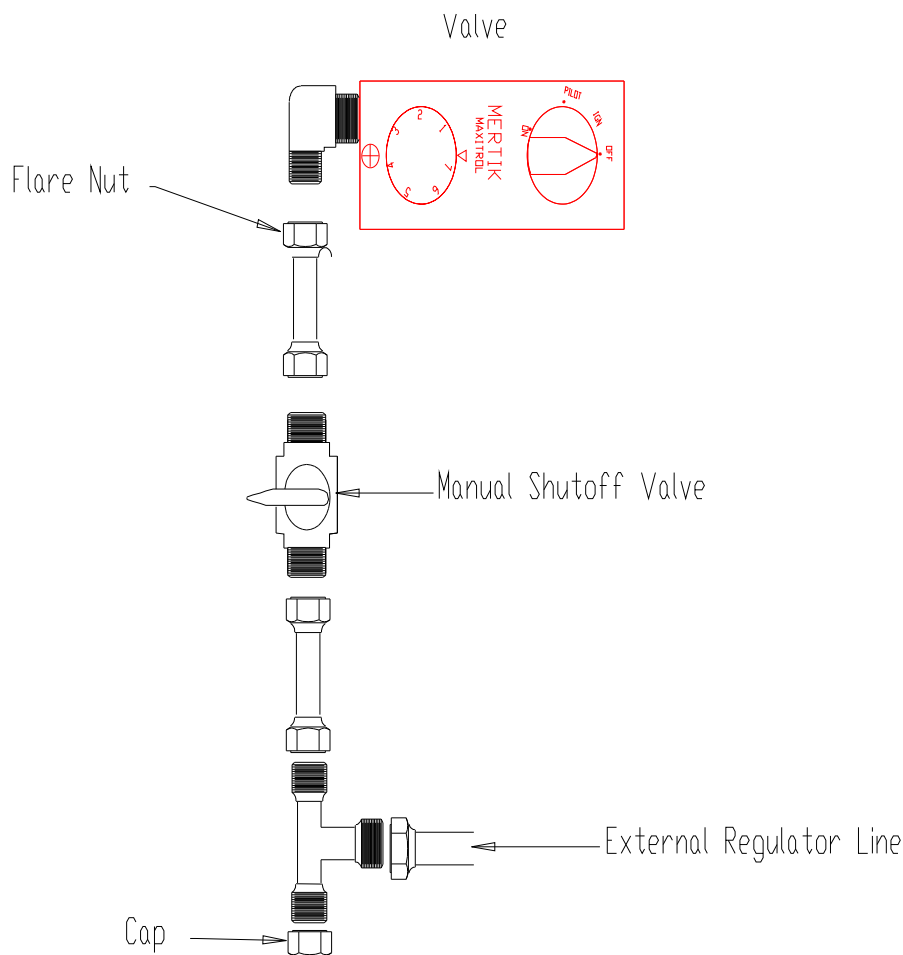

Figure 11

GAS PRESSURE CHECK

Check the inlet pressure to the burner to insure that it is as shown in the table below.

NOTE: The pressure check point is located on the right side of the valve facing burner.

The appliance and its appliance main gas valve must be disconnected from the gas supply piping system during any pressure testing of that system at test pressures in excess of 1/2 psi (3.5kPa).

The appliance must be isolated from the gas supply piping system by closing its equipment shut-off valve during any pressure testing of the gas supply piping system at test pressures equal to or less than 1/2 psi (3.5 kPa).

MODEL	1110	1110
Gas	Natural	Propane
Maximum Heat Input	10000	10000
Gas Inlet Pressure:		
Maximum	10.5 ins. W.C.	13 ins. W.C.
Minimum	* 5 ins. W.C.	*11 ins. W.C.
Manifold Pressure	3.5 ins. W.C.	9 ins. W.C.

NOTE: On initial installation it may be necessary to bleed out air in the gas lines. Do this by holding the control knob and turning the knob to the pilot position for about 30 seconds.

To check the Regulator pressure, remove the pressure tag plug at the left side of the Regulator facing the heater. The pressure should be checked with the heater burning and the control set on high. After measuring the pressure, replace the pressure tap plug, ensuring that there are no leaks.

* For the purpose of minimum input adjustment.

WARNING
This appliance is equipped for (natural or propane) gas.
Field conversion is not permitted.

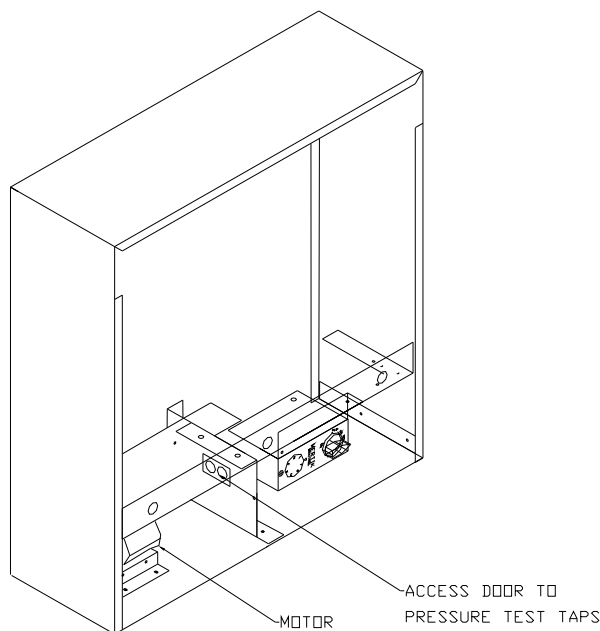

Figure 12

LOG PLACEMENT FOR 1110

Logs are shipped secured in unit.

NOTE: When operated for the first time, logs may emit a “paper burning” smell. This smell will gradually diminish and will be totally eliminated after the first few hours of operation. Do not use the blower at this time.

Front View of Logs

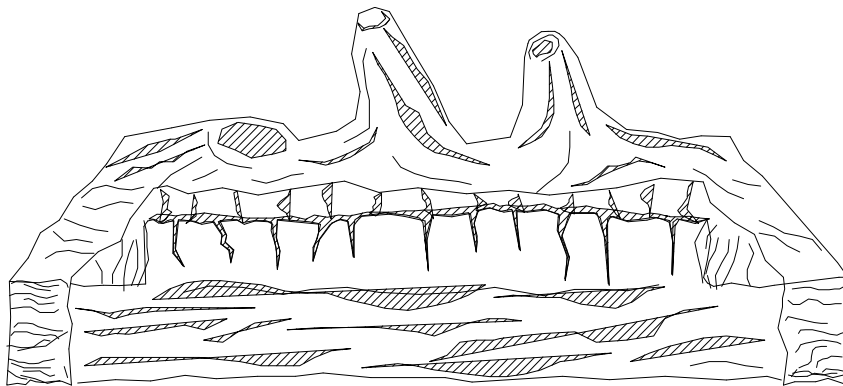

WARNING

“FAILURE TO POSITION THE PARTS IN ACCORDANCE WITH THESE DIAGRAMS OR FAILURE TO USE ONLY PARTS SPECIFICALLY APPROVED WITH HEATER MAY RESULT IN PROPERTY DAMAGE OR PERSONAL INJURY.”

WARNING

“DO NOT ALLOW FANS TO BLOW DIRECTLY INTO THE FIREPLACE. AVOID ANY DRAFTS THAT ALTER BURNER FLAME PATTERN.”

OPERATING INSTRUCTIONS

Before operating this appliance, proceed through the following checklist

1. Read and understand these instructions before operating this appliance.
2. Check that there no leaks. If you smell gas do not attempt to light this appliance.

LIGHTING INSTRUCTIONS MODULATING VALVE(MAXITROL) FOR YOUR SAFETY, READ BEFORE LIGHTING

WARNING

IF YOU DO NOT FOLLOW THESE INSTRUCTIONS EXACTLY, A FIRE OR EXPLOSION MAY RESULT CAUSING PROPERTY DAMAGE, PERSONAL INJURY OR LOSS OF LIFE.

- A. This appliance has a pilot which must be lighted by hand. When lighting the pilot, follow these instructions exactly.
- B. **BEFORE LIGHTING:** Smell all around the appliance for gas. Be sure to smell next to the floor because gas is heavier than air and will settle on the floor.

WHAT TO DO IF YOU SMELL GAS

- * Do not try to light any appliance.
 - * Do not touch any electrical switch; do not use any phone in your building.
 - * Immediately call your gas supplier from a neighbor's phone. Follow the gas supplier's instructions.
 - * If you cannot reach your gas supplier, call your local fire department.
- C. Use only your hand to push in or turn the gas control knob. Never use tools. If the knob will not push in or turn by hand, don't try to repair it, call a qualified service technician. Force or attempted repair may result in fire or explosion.
 - D. Do not use this appliance if any part has been under water. Immediately call a qualified service technician to inspect the appliance and to replace any part of the control system and any gas control which has been under water.

LIGHTING INSTRUCTIONS

1. STOP! Read the safety information on the previous page.
2. Make sure manual shutoff valve is fully **closed**.
3. Open access panel door, located in lower front center of base for access to control knobs.
4. Turn off all electric power to the appliance.
5. Set thermostat (flame control) to lowest setting.
6. Push in and turn control knob clockwise  to the **“OFF”** position.

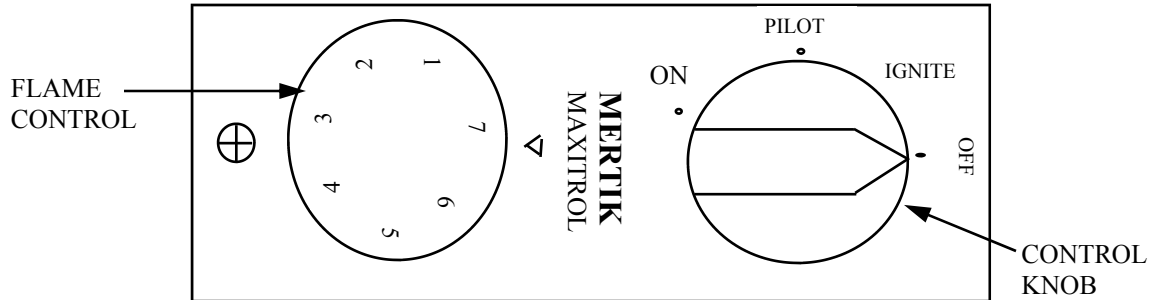





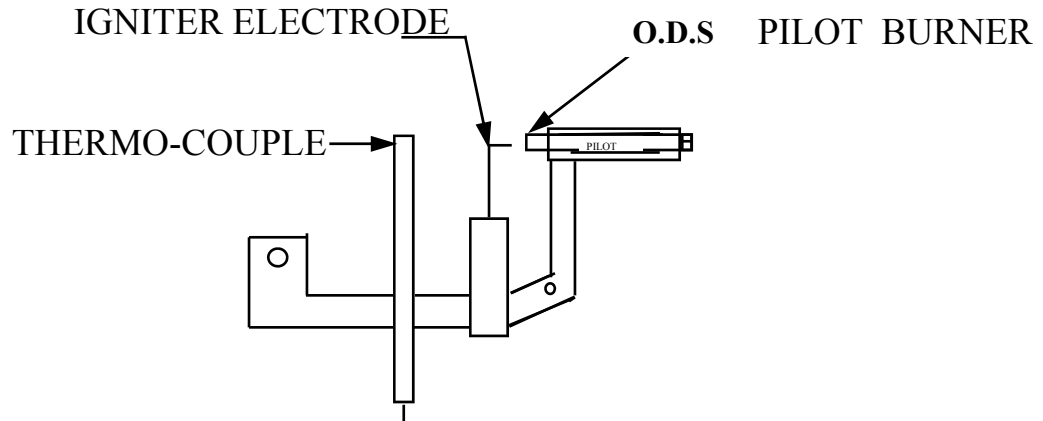

FIGURE 3

7. “Wait (5) five minutes to clear out any gas. Then smell for gas, including near the floor. If you smell gas, STOP! Follow step “B” in the safety information on the previous page. If you don’t smell gas, go to the next step.”
8. Find Pilot: follow the small metal tube from the right hand rear of the gas control valve. The pilot is located behind the burner tube and in front of the rear log. Fully **open** the manual shut-off valve.
9. Turn control knob counterclockwise  to the **“PILOT”** position. Press in control knob for (15) fifteen seconds (see figure 3).
10. With control knob pressed in, turn control knob clockwise  to **IGNITE** and then **immediately back** to **PILOT** with the button still pressed in. This will light the pilot. If needed, keep repeating this step until pilot lights.
11. Keep control knob pressed in for one (1) minute after lighting pilot. After (1) minute, release the control knob. If pilot goes out, repeat steps 1 through 9.
 - If the knob does not pop up when released, stop and immediately call your service technician or gas supplier.
 - “If the pilot will not stay lit after several tries, turn the gas control knob to **“OFF”** and call your service technician or gas supplier.”
12. Turn control knob counterclockwise  to **“ON”** position.
13. “Set thermostat (flame control) to desired setting. Turn clockwise  for **“LOW”** and counterclockwise  for **“HIGH”**.”



14. Close the access panel door.
15. "Turn on all electric power to the appliance."

CAUTION

DO NOT TRY TO ADJUST HEATING LEVELS BY USING THE MANUAL SHUTOFF VALVE.

TO TURN OFF GAS TO APPLIANCE

SHUTTING OFF UNIT:

1. Open access panel door, located in lower front center of base for access to control knobs.
2. Set thermostat (flame control) to lowest setting.
3. Turn control knob clockwise to the full "OFF" position.
4. "Turn off all electrical power to the appliance if service is to be performed."
5. Close access panel door.

SHUTTING OFF BURNER ONLY (pilot stays lit)

1. Open access panel door, located in lower front center of base for access to control knobs.
2. Turn control knob clockwise to the "PILOT" position.
3. Close access panel door.

CAUTION: Hot while in operation. Do Not Touch. Keep children, clothing, furniture, gasoline, and other liquids having flammable vapors away.

CAUTION: DO NOT TRY TO ADJUST HEATING LEVELS BY USING THE MANUAL SHUTOFF VALVE.

WARNING: Improper installation, adjustment, alteration, service or maintenance can cause property damage, personal injury, or loss of life. Refer to owner's information manual provided with this appliance. Installation and service must be performed by a qualified installer, service agency, or the gas supplier.





IMPORTANT: Always operate the appliance at the completely "ON" or the completely "OFF" positions. Never use the heater at a setting between these positions as this can result in improper combustion and excessive carbon monoxide emissions.

THERMOSTAT CONTROL OPERATION

The thermostat control used on this heater differs from standard thermostats. Standard thermostats simply turn the burner on and off. The thermostat used on this heater senses the room temperature and adjusts the amount of gas flow to the burner. This will increase or decrease the flame height. At times, the room may exceed the set temperature, which will cause the burner to shut off. When room temperature drops below the thermostat setting, the burner will cycle itself on again. The flame control knob can be set to any level between 2 and 7.

NOTE: The thermostat sensing bulb measures the temperature of air near the heater cabinet. This may not always agree with room temperature (depending on housing construction, installation location , room size, open air temperature,etc.). Frequent use of your heater will allow you to determine your personal comfort levels.

MANUAL LIGHTING PROCEDURE

1. If the pilot cannot be ignited with the ignitor on the control valve, it can be manually lit with the use of a paper match and a lighter rod.
2. Place the match in the holder and light. With other hand, depress the control knob counterclockwise  to PILOT.
3. Use rod to light match and ignite pilot. The pilot is located behind the burner tub and in front of the rear log. Fully **open** the manual shut-off valve.
4. Continue to hold the control knob for an additional (1) one minute to ensure the pilot is completely on.
 - If the knob does not pop up when released, stop and immediately call your service technician or gas supplier.
 - “If the pilot will not stay lit after several tries, turn the gas control knob to “OFF” and call your service technician or gas supplier.”
5. Turn control knob counterclockwise  to “ON” position.
“Set thermostat (flame control) to desired setting. Turn clockwise  for “LOW” and counterclockwise  for “HIGH”.
6. Close the access panel door.
7. “Turn on all electric power to the appliance.”

FLAME CHECK

A periodic check of the flames should be made. The pilot flame should always be present when the gas logs are in operation.

FLAME: Propane (LP) should produce a flame that is 3"-4" above rear log. This flame should be yellow.

Natural gas should produce a flame that is 3"-4" above rear log. This flame should be mostly blue except for the top 1/2" which should be yellow.

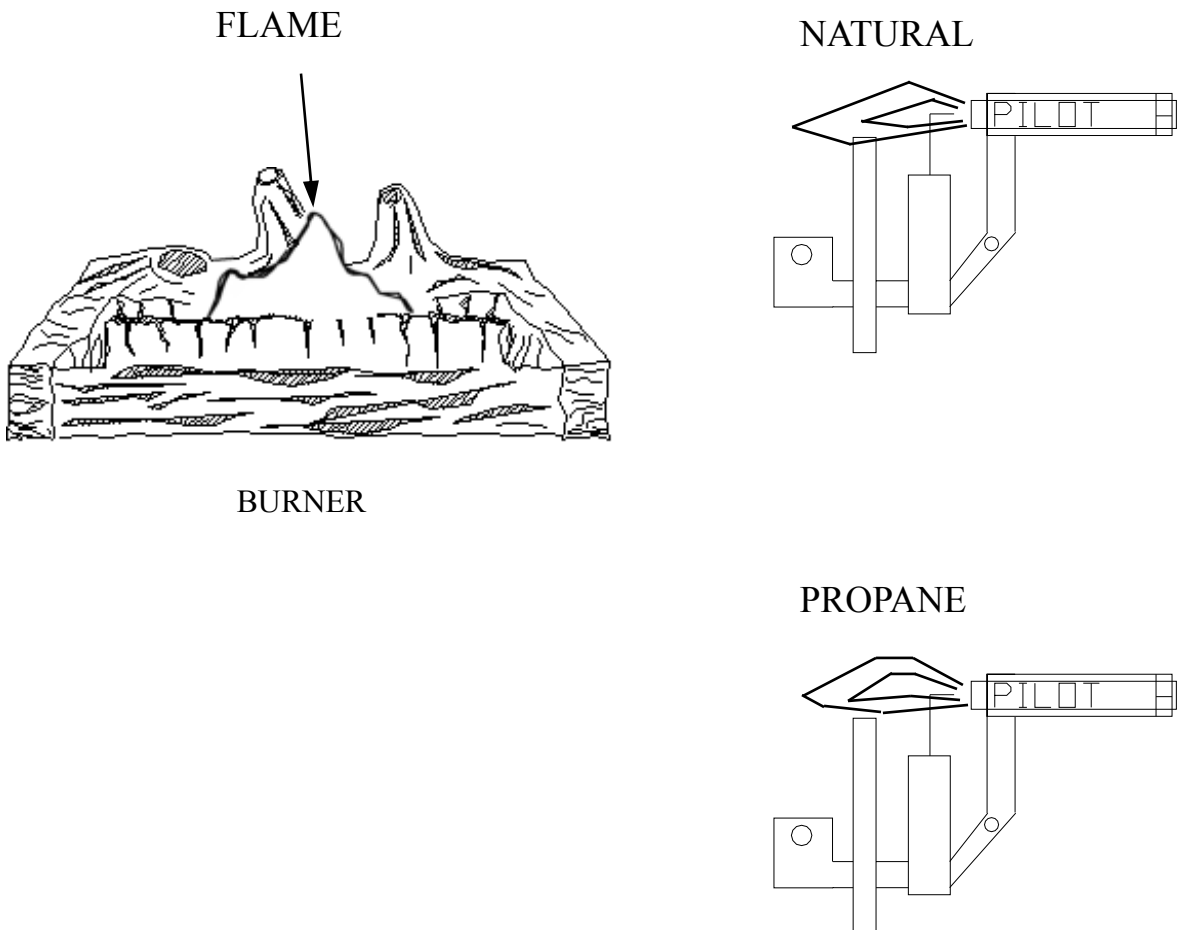
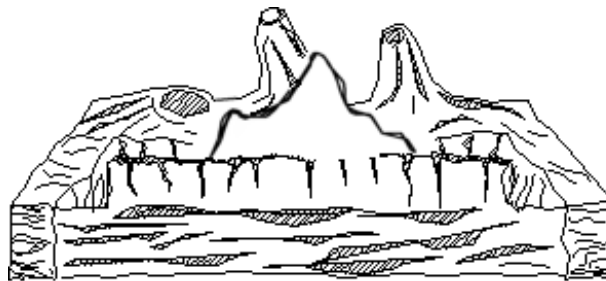

FIGURE 17

BURNER FLAME PATTERN

Figure 18 shows a correct burner flame pattern. Figure 19 shows an incorrect burner flame pattern.

NOTE: When using the heater the first time, the logs will emit a paper like odor for about one hour.



CORRECT FLAME PATTERN
AT HIGH POSITION

Figure 18 - Correct Burner Flame Pattern □

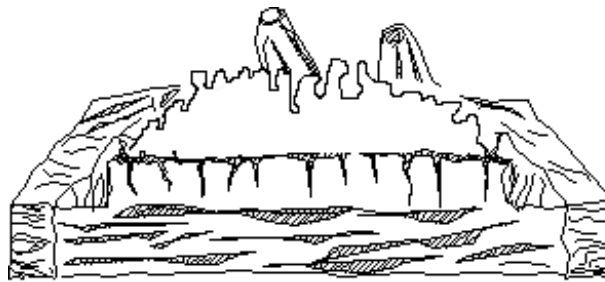

INCORRECT FLAME PATTERN
AT HIGH POSITION

Figure 19 - Incorrect Burner Flame Pattern □

If burner flame pattern is incorrect, as shown in Figure 19
*turn heater OFF (see “To Turn Off Gas to Appliance”, page 28.
*see “Troubleshooting”, pages 35 through 39.

WARNING: CHILDREN AND ADULTS SHOULD BE ALERTED TO THE HAZARDS OF HIGH SURFACE TEMPERATURE AND SHOULD STAY AWAY TO AVOID BURNS OR CLOTHING IGNITION. YOUNG CHILDREN SHOULD BE CAREFULLY SUPERVISED WHEN THEY ARE IN THE SAME ROOM WITH THE APPLIANCE.

WARNING: DO NOT PLACE CLOTHING OR OTHER FLAMMABLE MATERIALS ON OR NEAR THE APPLIANCE.

WIRING DIAGRAM

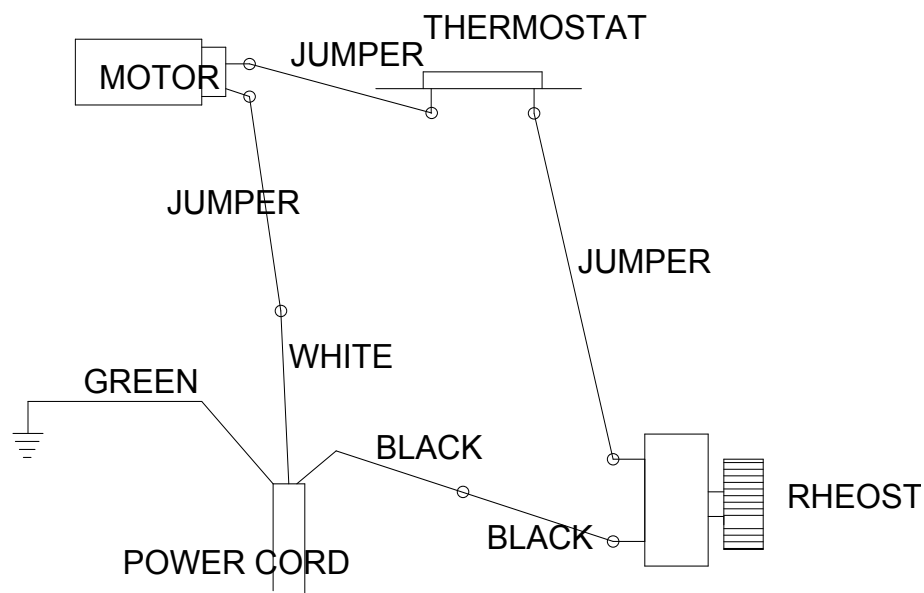

Figure 10

NOTE: “If any of the original wire as supplied with the appliance must be replaced, it must be replaced with a wire of at least a 105° C. temperature rating.”

NOTE: Installation and repair should be done by a qualified service person. This heater should be inspected before use and at least annually by a qualified service person. More frequent cleaning may be required due to excessive lint from carpeting, bedding material, etc. It is imperative that control compartments and circulating air passageways of the heater be kept clean.

CAUTION: Label all wires prior to disconnection when servicing controls. Wiring errors can cause improper and dangerous operation.

Verify proper operation after servicing.

WARNING: ELECTRICAL GROUNDING INSTRUCTION: THIS APPLIANCE IS EQUIPPED WITH A THREE-PRONG (GROUNDING) PLUG FOR YOUR PROTECTION AGAINST SHOCK HAZARD AND SHOULD BE PLUGGED DIRECTLY INTO A PROPERLY GROUNDED THREE-PRONG RECEPTACLE.

NOTE: #PE A24001 Blower Motor
Rating: 120 volts/60MZ/0.54 Amps. 1 P.H.

Blower Motor is standard on all Model 1110. See page 38 for blower motor location.

NOTE: For convenience, allow licensed electrician to properly install a grounded 3-plug receptacle near the unit.

SERVICING

Repair and replacement work should only be performed by a qualified service technician.

Always shut off the gas supply and make sure heater is cool before beginning any service operation. Check for gas leaks after servicing.

REPAIR PARTS

A parts list with exploded view follows. Always include correct name, part number, and model number of the heater when ordering service parts. Please contact your local dealer or distributor when ordering. If one is not available, you may contact:

New Buck Corporation
8000 Highway 226 South
Spruce Pine, NC 28777

828-765-6144

IMPORTANT SAFEGUARDS

Although your gas logs are very realistic in appearance, it is not a real burning fireplace and must not be used for burning rejected material.

- To avoid irreparable damage to the heater or personal injury, matches, paper, garbage, or any other material **must not** be placed or thrown on top of the logs or into the flames.
- To avoid personal injury, do not touch hot surfaces when the heater is operating.
- Close supervision is necessary when the heater is being operated near children.

WARNING: THE LOGS ARE MANUFACTURED FROM BONDED CERAMIC FIBER. THIS IS A COMMONLY USED MATERIAL IN INDUSTRY WORLDWIDE. IN THE EVENT THAT A LOG SHOULD BE REMOVED, CARE SHOULD BE TAKEN NOT TO DAMAGE THE BONDED MATERIAL. INTENTIONAL MISUSE OR DELIBERATELY FRAGMENTING THE MATERIAL COULD LEAD TO INHALING FIBERS AND BE HAZARDOUS TO YOUR HEALTH.

THIS HEATER IS INTENDED FOR USE AS A GAS HEATER FIREPLACE AS DESCRIBED IN THESE INSTRUCTIONS. IT SHOULD NOT BE USED FOR ANY OTHER PURPOSE.

CLEANING

CAUTION: BEFORE CLEANING OR MOVING THESE LOGS OR OTHER PARTS OF THE HEATER, BE SURE TO READ THE ABOVE SECTIONS ON “IMPORTANT SAFEGUARDS.”

See page 10, figure 6 before cleaning. The appliance must be turned “OFF” before cleaning inside the firebox (burn area), make sure the pilot is “OFF” completely and the appliance has cooled.

- All cleaning should be carried out when the heater is cold. Limited cleaning is required with normal use. Dusting the front of the base, the top of the piezo cover, or the control knob panel may be required occasionally. Do not use cleaning fluids to clean the logs or any other part of the heater.
- If the flames show unusual shapes or behavior, or if burner fails to ignite properly, the burner holes may require cleaning. If this occurs, contact your nearest dealer to service the heater.
- The heater can be cleaned by removing the logs. Lift the logs gently, as not to damage the fiber pieces. The logs have been spot glued in place for shipping, use caution when removing. Lift each log by holding it carefully at each end. Use a vacuum cleaner to remove dust and loose particles from the base, logs and around the burner and ODS/Pilot. Gloves are recommended to prevent fibers from breaking the skin. If skin is broken, clean with soap and water.

WARNING: Failure to keep the primary air openings(s) of the burner(s) clean may result in sooting and property damage.

TROUBLE-SHOOTING

WARNING

TURN OFF AND UNPLUG HEATER AND LET COOL BEFORE SERVICING. ONLY A QUALIFIED SERVICE PERSON SHOULD SERVICE AND REPAIR HEATER.

CAUTION

NEVER USE A WIRE, NEEDLE, OR SIMILAR OBJECT TO CLEAN ODS/PILOT. THIS CAN DAMAGE ODS/PILOT.

WARNING: Installation and repairs should be performed by a qualified service person. The appliance should be inspected before use and at least annually by a professional service person. More frequent cleaning may be required due to excessive lint from carpeting, bedding material, etc. It is imperative that control compartments, burners and circulating air passageways of the appliance be kept clean.

See pages 32 through 35 for Trouble Shooting.

OBSERVED PROBLEM	POSSIBLE CAUSE	SOLUTION
1. Igniter button is pressed. No spark at ODS/Pilot	1. Igniter electrode positioned incorrectly 2. Igniter electrode broken 3. Igniter electrode not connected to igniter cable 4. Igniter cable pinched or wet 5. Piezo igniter nut is loose 6. Broken igniter cable 7. Bad piezo igniter	1. Replace igniter 2. Replace igniter 3. Reconnect igniter cable 4. Free igniter cable if pinched by any metal or tubing. Keep igniter cable dry. 5. Tighten nut holding piezo igniter to heater cabinet. Nut is located inside heater cabinet at top. 6. Replace igniter cable 7. Replace piezo igniter
2. Igniter button is pressed Spark at ODS/Pilot No Ignition	1. Gas supply turned off or manual shutoff valve is closed 2. Control knob not in "PILOT" position 3. Control knob not pressed in while in "PILOT" position 4. Air in gas lines when installed 5. Depleted gas supply 6. ODS/Pilot is clogged 7. Gas regulator setting is not correct	1. Turn on gas supply or open manual shutoff valve 2. Turn control knob to "PILOT" position 3. Press in control knob while in "PILOT" position. 4. Continue to hold down control knob. Repeat igniting operation until air is removed. 5. Contact local propane gas company 6. Clean ODS/Pilot or replace ODS/Pilot assembly 7. Replace gas regulator

OBSERVED PROBLEM	POSSIBLE PROBLEM	SOLUTION
3. ODS/PILOT lights but flame goes out when control knob is released	1. Control knob is not fully pressed in 2. Control knob not pressed in long enough 3. Safety interlock system has been triggered (if equipped) 4. Manual shutoff valve not fully open 5. Thermocouple connection loose at control valve. 6. Pilot flame not touching thermocouple, which allows thermocouple to cool, causing pilot flame to go out. This problem can be caused by one or both of the following: A) low gas pressure B) dirty or partially clogged ODS/Pilot 7. Control valve damaged	1. Press control knob completely 2. After ODS/Pilot lights keep control knob pressed 30 seconds 3. Wait 1 minute for safety interlock system to reset. 4. Fully open manual shutoff valve 5. Hand tighten until snug, then tighten 1/4 turn 6. A) Contact local propane gas company B) Clean ODS/Pilot (See “Cleaning and Maintenance”), or replace ODS/Pilot assembly 7. Replace valve control
4. Burner does not light after ODS/Pilot is lit	1. Burner orifice is clogged 2. Inlet gas pressure is too low	1. Clean burner (see “Cleaning and Maintenance”) or replace burner orifice 2. Contact local propane gas company

OBSERVED PROBLEM	POSSIBLE CAUSE	SOLUTION
5. Delayed ignition of burner	<ol style="list-style-type: none"> 1. Manifold pressure is too low 2. Burner orifice is clogged 	<ol style="list-style-type: none"> 1. Contact local propane gas company 2. Clean burner (see “Cleaning and Maintenance”) or replace burner orifice
6. Burner backfiring during combustion	<ol style="list-style-type: none"> 1. Burner orifice is clogged or damaged 2. Burner damaged 3. Gas regulator defective 	<ol style="list-style-type: none"> 1. Clean burner (see “Cleaning and Maintenance”) or replace burner orifice 2. Replace burner 3. Replace gas regulator
7. Slight smoke or odor during initial operation	<ol style="list-style-type: none"> 1. Residues from manufacturing process 	<ol style="list-style-type: none"> 1. Problem will stop after a few hours of operation
8. Heater produces a whistling noise when burner is lit	<ol style="list-style-type: none"> 1. Turning control knob to “HI” position when burner is cold (if equipped with this type of valve) 2. Air in gas line 3. Air passageways on heater blocked 4. Dirty or partially clogged burner orifice 	<ol style="list-style-type: none"> 1. Turn control knob to “LOW” position and allow to warm 2. Operate burner until air is removed from line. Call local propane company to check gas line. 3. Observe minimum installation clearances 4. Clean burner or replace orifice

WARNING

IF YOU SMELL GAS:

- * **SHUT OFF GAS SUPPLY**
- * **DO NOT TRY TO LIGHT APPLIANCE**
- * **DO NOT TOUCH ANY ELECTRICAL SWITCH; DO NOT USE ANY PHONE IN YOUR BUILDING**
- * **IMMEDIATELY CALL YOUR GAS SUPPLIER FROM A NEIGHBOR'S PHONE. FOLLOW THE GAS SUPPLIER'S INSTRUCTIONS.**
- * **IF YOU CANNOT REACH YOUR GAS SUPPLIER, CALL THE FIRE DEPARTMENT.**

IMPORTANT: Operating heater where impurities in the air exist may create odors. Cleaning supplies, paint, paint remover, cigarette smoke, cements and glues, new carpet or textiles, etc. create fumes. These fumes may mix with combustion air and create odor.

OBSERVED PROBLEM	POSSIBLE CAUSE	SOLUTION
1. Heater produces a clinking/ticking noise just after burner is lit or shut off	1. Metal expands while heating or contracts while cooling.	1. This is common with most heaters. If noise is excessive, contact a qualified service person.
2. Heater produces unwanted odors	1. Heater burning vapors from paint, hairspray, glues, etc. (See Important above) 2. Low fuel supply 3. Gas leak (See WARNING above)	1. Ventilate room. Stop using odor causing products while heater is running. 2. Refill supply tank. 3. Locate and control all leaks. See "Checking Gas Connections".
3. Heater shuts off in use (ODS operates)	1. Not enough fresh air is available. 2. Low line pressure 3. ODS/Pilot is partially clogged	1. Open window/door for ventilation 2. Contact local propane co. 3. Clean ODS/Pilot
4. Gas odor even when control knob is in "OFF" position	1. Gas leak (See WARNING , above). 2. Control valve defect	1. Locate and correct all leaks (see Checking Gas Connections) 2. Replace control valve
5. Gas odor during combustion	1. Foreign matter between control valve and burner 2. Gas leak (See WARNING above).	1. Remove foreign matter from gas tubing 2. Locate and correct all leaks (see "Checking Gas Connections").

TECHNICAL SERVICE

MODEL 1110

MODULATING VALVE

BTU.	10,000	10,000
Type Gas	Propane (LP)	Natural
Ignition	Piezo	
Pressure Regulator Setting	9" W.C.	3.5" W.C.
Inlet Gas Pressure (in. of water)*		
Maximum	14"	10.5" W.C.
Minimum	11"	5.0" W.C.
Dimensions, Inches (HxWxD)		
Heater	22" x 20 - 1/8" x 7"	
Weight (pounds)		
Heater	45 pounds	
Shipping		

* For purposes of input adjustment

PARTS LIST

KEY NO.	PART NUMBER	DESCRIPTION	QUANTITY
1	MF 112738	VENT ROD	3
2	PO 1127IM	BRASS TRIM	4
3	PO PNPSNH50JT	FRONT	1
4	MA 1127SC	FRONT SCREEN	1
5	P0 112706	INNER SHIELD CHROME	1
6	MF 112782	LOG HOLDER	2
7	A2-40-01	FAN MOTOR	1
8	PS 112724	MOTOR BRACE	1
9	PS 112740	SCREEN MOTOR COVER	1
10	PE KB9724	FAN SPEED CONTROL LABEL	1
11	PE BC204	RHEOSTAT	1
12	PE BC204A	RHEOSTAT KNOB	1
13	PE 400132	110 DEG. DISC THERMOSTAT	1
14	PE 30JUMPER	THERMO JUMPER WIRE	2
15	PE 400320	STRAIN RELIEF	1
16	PE 400240	POWER CORD	1
17	PO 22GAJ1712	BRASS COVER DOOR LOUVER	3
18	PO WALLMT	LOG SET	1
19	PH 101612PHPTEK	SCREW, #10 x 1/2" PAN	2
20	PH101634TEK	SCREW, #10 x 3/4" HEX	2
21	PH 103212HWSPS5	SCREW, #10 x 1/2" HEX	6
22	PH 6114DWPILSC	DRYWALL SCREW, 6" x 1 1/2"	2

BLOWN UP VIEW OF HEATER, FAN MOTOR, AND ALL REMOVABLE PARTS

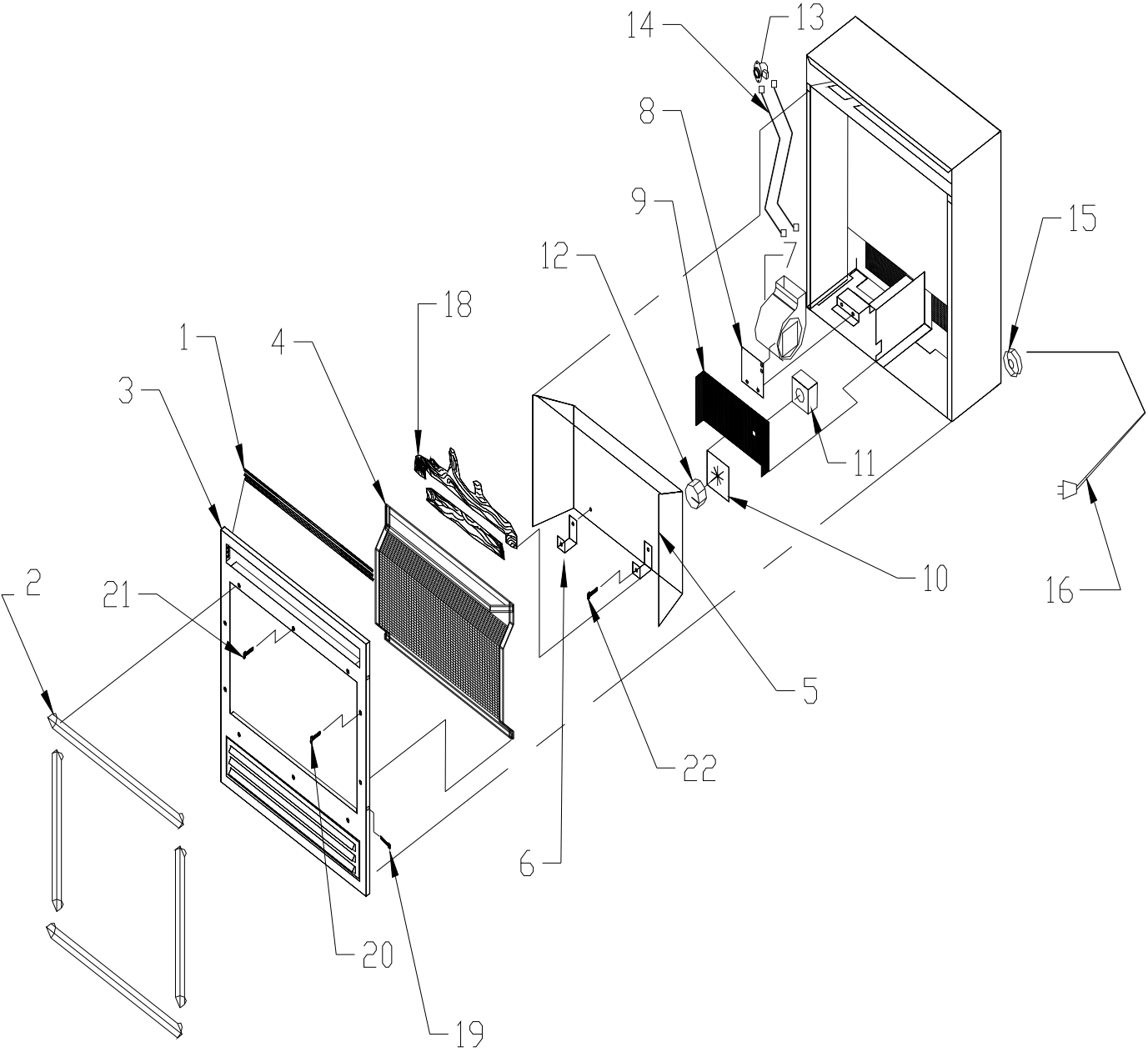

PARTS LIST

Maxitrol Valve

KEY #	PART #	DESCRIPTION	QUANTITY
1	GV 30B5A2L7B	Maxitrol LP Valve	1
1A	GV 30B5A2N7B	Maxitrol Nat. Valve	1
2	PE 4966	3/8" - 3/8" Elbow	1
3	PS 112736	Maxitrol Regulator Holder	1
4	PS 1024	BR 10 Burner Base	1
5	PO BR10 Burn	Single Burner	1
6	PE TPT100/433	Thermo-couple/ (Copreci)	1
7	PE 21500053	Copreci ODS Nat. Pilot	1
7A	PE 2150054	Copreci ODS LP Pilot	1
8	PE RV12LF30	Maxitrol Regulator-Nat.	1
8A	PE RV12LF90	Maxitrol Regulator-LP	1
9	RF 14ALMTUB	1/4" Aluminum Tubing	1
10	PH 1166	3/8" Street Elbow	1
11	PE 6482	1/4" -1/8" Compression Adapter	2
12	PO Orifice	Orifice Nat. or LP	1
13	PS 112726	M1127 Burner Supports	2
14	PO 38634ALMTUB	3/8" x 6 - 3/4" Burner Tube	1
15	PO 54ORFHLD	Angled Orifice Holder	1

BLOWN UP VIEW OF BURNER ASSEMBLY

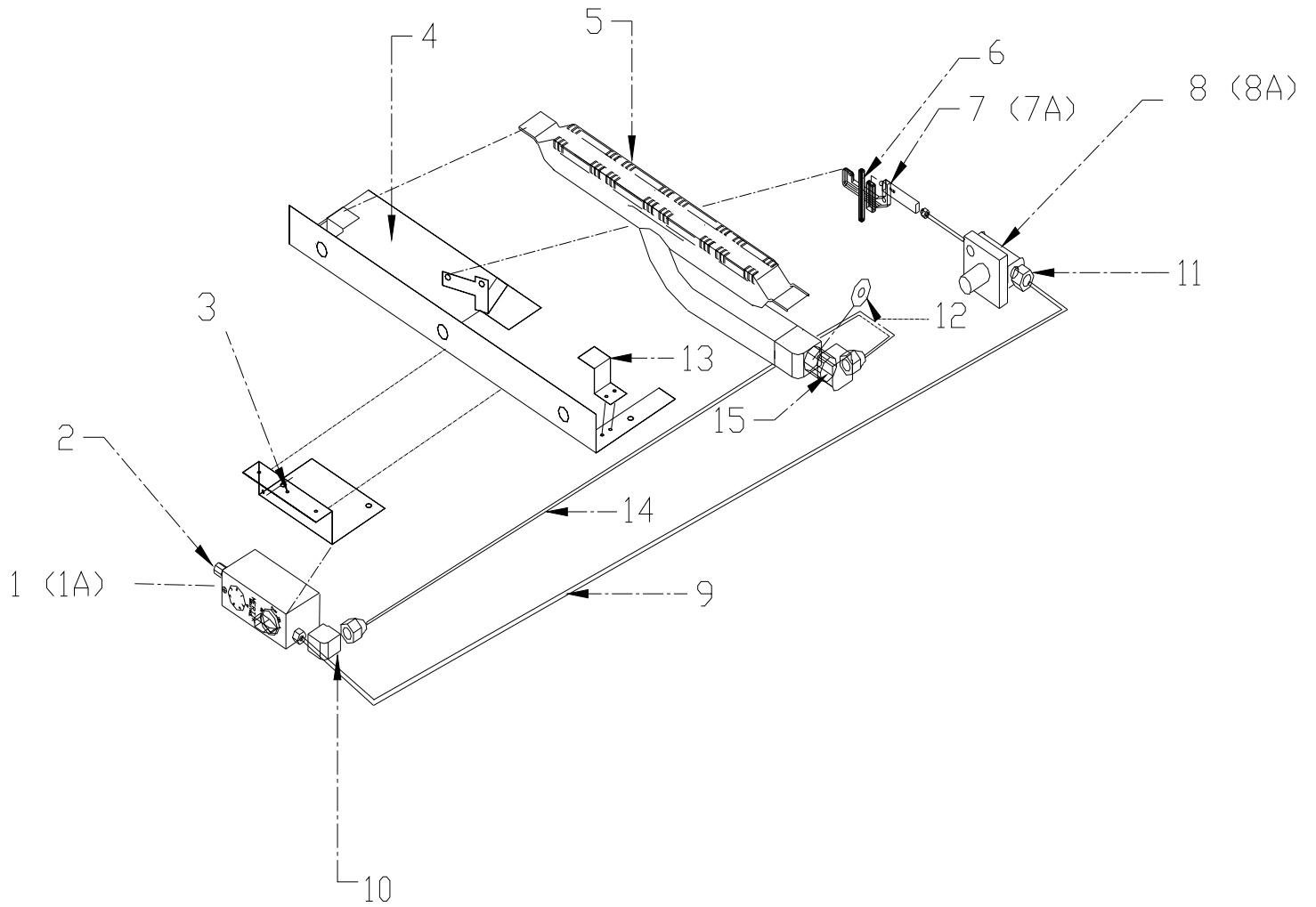

NEW BUCK CORPORATION

We reserve the right to amend these specifications at any time without notice. The only warranty applicable is our standard written warranty. We offer no other warranty, expressed or implied.

LIMITED WARRANTY ON VENT-FREE GAS LOG HEATER

New Buck warrants this product to be free from defects in materials and components for two (2) years from the date of first purchase, provided that the product has been properly installed, operated, and maintained in accordance with all applicable instructions. To make a claim under this warranty the Bill of Sale or canceled check must be presented.

This warranty is extended only to the original retail purchaser and covers the cost of parts required to restore the heater to proper condition. Warranty parts **MUST** be obtained through an authorized Buck Stove dealer and/or New Buck, who will provide original factory replacement parts. Failure to use original factory replacement parts voids this warranty. The heater must be installed by a qualified installer in accordance with all local codes and instructions furnished with the unit.

Warranty does not apply to parts that are not in original condition, normal wear and tear, or parts that fail or become damaged as a result of misuse, accidents, lack of proper maintenance or defects caused by improper installation.

WARRANTY DOES NOT COVER:

- Removal and re-installation cost
- Labor costs for replacements or repairs
- Transportation
- Cost of service call to diagnose problem
- Painted surfaces
- Damage or defect caused by improper installation, accident, misuse, abuse, or alteration

TO THE FULL EXTENT ALLOWED BY THE LAW OF THE JURISDICTION THAT GOVERNS THE SALE OF THE PRODUCT, THIS EXPRESS WARRANTY EXCLUDES ANY AND ALL OTHER EXPRESSED WARRANTIES AND LIMITS THE DURATION OF ANY AND ALL WARRANTIES, INCLUDING WARRANTIES OF MERCHANTABILITY AND FITNESS FOR A PARTICULAR PURPOSE TO ONE (1) YEAR FROM THE DATE OF FIRST PURCHASE. NEW BUCK LIABILITY IS HEREBY LIMITED TO THE PURCHASE PRICE OF THE PRODUCT AND NEW BUCK SHALL NOT BE LIABLE FOR ANY OTHER DAMAGES WHATSOEVER INCLUDING INCIDENTAL OR CONSEQUENTIAL DAMAGES.

Some states do not allow a limitation on how long an implied warranty lasts or an exclusion or limitation of incidental or consequential damages, so the above limitation on implied warranties, or exclusion on damages may not apply to you.

This warranty gives you specific legal rights. Other rights may vary from state to state.